



DATA SOUND - LABORATORIES -

.....
EMBEDDING THE FUTURE



**Electronic
Design**



**Panel
PC / HMI**

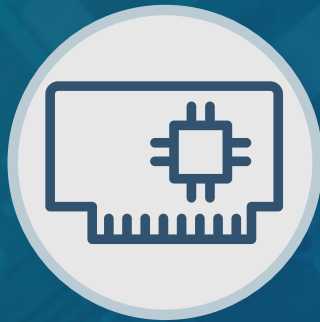

**Single Board
Computer**



**Industrial
PC**

Why choose DSL?

- Over 25 Years Industry Experience
- 5 Years Warranty on all Products
- Evaluation Products Available
- Lifetime Technical Support

Our Services

- Electronic Design
- Production Management
- Assembly and Test
- Bespoke BIOS Creation
- Industrial Embedded PC Solutions



Call us on +44(0)1462 675530



Email us at sales@dsl-ltd.co.uk



www.dsl-ltd.co.uk

Features

- 17" Industrial Compact Size Panel PC
- Intel Apollo Lake N4200/N3350
- On Board 4G/8G DDR3L 1866MHz
- Flat front panel touch screen
- IP66 compliant front panel
- Optional projected capacitive touchscreen support 7H anti-scratch surface
- DC 9~36V wide-ranging power input
- High Brightness 1,000 nits for option

Specifications

System	
CPU	Onboard Intel Apollo Lake N4200 (4 Core, 1.1GHz) / N3350 (2 Core, 1.1GHz)
System Chipset	SoC
Memory	On Board 4G/8G DDR3L 1866MHz

I/O Port	
USB	2 x USB 3.0 type A
Serial / Parallel	1 x DB-9 RS-232/422/485, COM1 (Default RS-232) 1 x RS-232 DB-9, COM2
Audio	1 x Audio Line Out
LAN	2 x GbE LAN RJ-45
Power	1 x 3-pin DC power input terminal 1 x 2-pin connector for power on/off button

Option	2 x RS-232 DB-9 + 1 x Mini-PCIe slot via TB-528C2ME1 2 x CAN bus via TB-528CAN2 2 x USB 2.0 type A + 1 x Mini-PCIe slot + 1xRS-232 DB-9 via TB-528C1U2P1 4 x USB 2.0 type A via TB-528U4 UPS Battery 21W/10.8W/1.95Ah(3S1P) UPS Battery and TB-528 expansion board can't be used in the same time
--------	---

Storage Space	
HDD	1 x 2.5" SATA HDD bay for SATA3 HDD (Easy Accessible)

Expansion	
Expansion Slot	1 x Internal Mini-PCIe slot full size 1 x SIM card holder / Micro SD card reader

Display	Standard	High Brightness Optional
Display Type	17" TFT-LCD	17" TFT-LCD
Max. Resolution	1280 x 1024	1280 x 1024
Max. Color	16.7M	16.7M
Luminance (cd/m ²)	350	1000
View Angle	160(H) / 170(V)	170(H) / 160(V)
Contrast	1000:1	1000:1
Backlight Lifetime	30,000 hrs	50,000 hrs

Touch Screen	
Type	Resistive Touch Window Projected Capacitive Touch (For P Model)
Interface	USB
Light Transmission(%)	Resistive Touch Window: over 80% Projected Capacitive Touch: over 90%

Dimensions

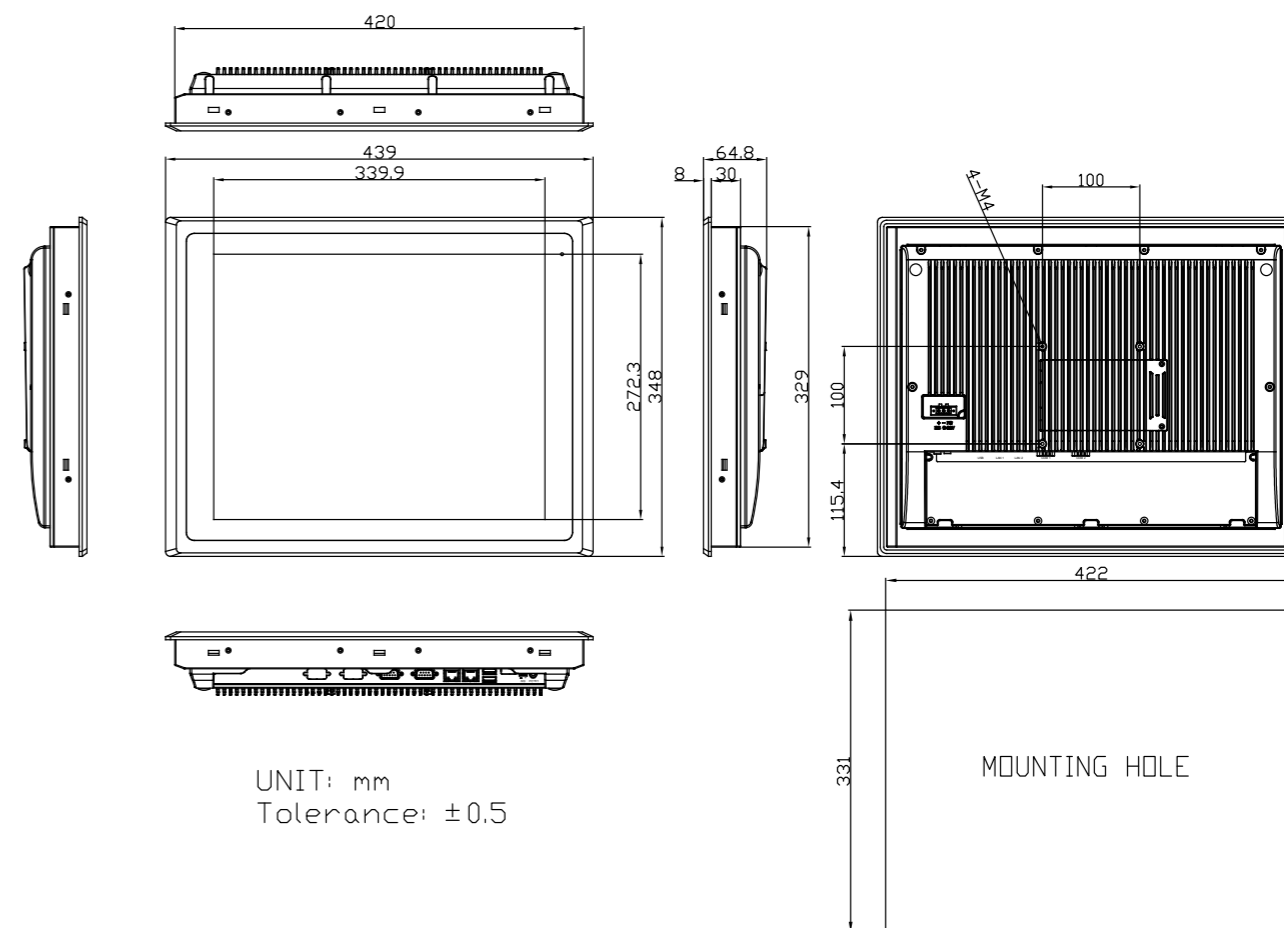

Power	
Power Input	DC 9~36V
Power Consumption	ARCHMI-817AP: TBD

Mechanical	
Color	RAL 9007
Construction	Aluminum front bezel/ Aluminum die-casting for back cover
Mounting	Panel Mount, VESA 100 x 100
Dimensions (WxHxD)	439mm x 348mm x 64.8mm
IP Rating	IP66 Compliant Front Bezel
Net Weight	5.1 kg

Environmental	
Operating Temperature	0~50°C
Storage Temperature	-30~70°C
Storage Humidity	10 to 90%@ 40°C, non-condensing
Certificate	CE/FCC Class A/CB/UL

Operating System Support	
Windows	Windows 10