



DATASOUND - LABORATORIES -

.....
EMBEDDING THE FUTURE



**Electronic
Design**



**Panel
PC / HMI**

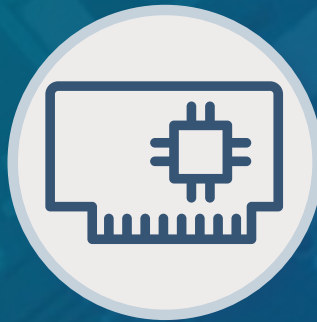

**Single Board
Computer**



**Industrial
PC**

Why choose DSL?

- Over 25 Years Industry Experience
- 5 Years Warranty on all Products
- Evaluation Products Available
- Lifetime Technical Support

Our Services

- Electronic Design
- Production Management
- Assembly and Test
- Bespoke BIOS Creation
- Industrial Embedded PC Solutions



Call us on +44(0)1462 675530



Email us at sales@dsl-ltd.co.uk



www.dsl-ltd.co.uk

Features

- 19" Industrial Compact Size Panel PC
- Intel Apollo Lake N4200/ N3350 (option)
- On Board 4GB/ 8GB DDR3L 1600MHz
- Flat front panel touch screen
- IP66 compliant front panel
- Optional projected capacitive touchscreen support 7H anti-scratch surface
- DC 9~36V wide-ranging power input
- High Brightness 1,000 nits for option

Specifications

System		
CPU	Onboard Intel Apollo Lake N4200 (4 Core, 1.1GHz) / N3350 (2 Core, 1.1GHz) (option)	
System Chipset	SoC	
Memory	Onboard 4GB/ 8GB (option) DDR3L 1600MHz	
I/O Port		
USB	2 x USB 3.0 type A	
Serial / Parallel	1 x DB-9 RS-232/422/485, COM1 (Default RS-232) 1 x RS-232 DB-9, COM2	
Audio	1 x Audio Line Out	
LAN	2 x GbE LAN RJ-45	
Power	1 x 3-pin DC power input terminal 1 x 2-pin connector for power on/off	
Option	VESA Stand 4G LTE/Wi-Fi/BT 4 x USB 2.0 type A(TB-528U4) 4 x USB 2.0 type A + 1 x Mini PCIe + 1 SIM slot (TB-528U4ME1) 1 x COM(RS-232) + 2 x USB 2.0 (TB-528C1U2) 1 x COM(RS-232) + 2 x USB 2.0 + 1 x Power Button (TB-528C1U2P1) 2 x COM(RS-232) (TB-528C2) 2 x COM(RS-232) + 1 x Mini-PCIe slot + 1 x SIM slot (TB-528C2ME1) 2 x COM(RS-232/485, isolated) (TB-528C2I) 2 x CAN (TB-528CAN2) 1 x LAN + 2 x USB 2.0 (TB-528E1U2) 1 x LAN + 2 x USB 2.0, 45W PoE (TB-528E1U2UPOE)* UPS Battery 21W/10.8Wh/1.95Ah(3S1P) System is only allowed to build in either I/O board TB-528 PoE series or UPS battery	
Storage Space		
HDD	1 x 2.5" SATA HDD bay for SATA3 HDD (Easy Accessible)	
Expansion		
Expansion Slot	1 x Internal Mini-PCIe slot full size 1 x SIM card holder / Micro SD card reader	
Display		
	Standard	High Brightness Optional
Display Type	19" TFT-LCD	19" TFT-LCD
Max. Resolution	1280 x 1024	1280 x 1024
Max. Color	16.7M	16.7M
Luminance (cd/m ²)	350	1000
View Angle	170(H) / 160(V)	170(H) / 160(V)
Contrast	1000:1	1000:1
Backlight Lifetime	50,000 hrs	50,000 hrs
Touch Screen		
Type	Resistive Touch (for AR Model) Projected Capacitive Touch (for AP Model) Glass (for AG model)	
Interface	USB	
Light Transmission(%)	Resistive Touch: over 80% Projected Capacitive Touch: over 90%	

Dimensions

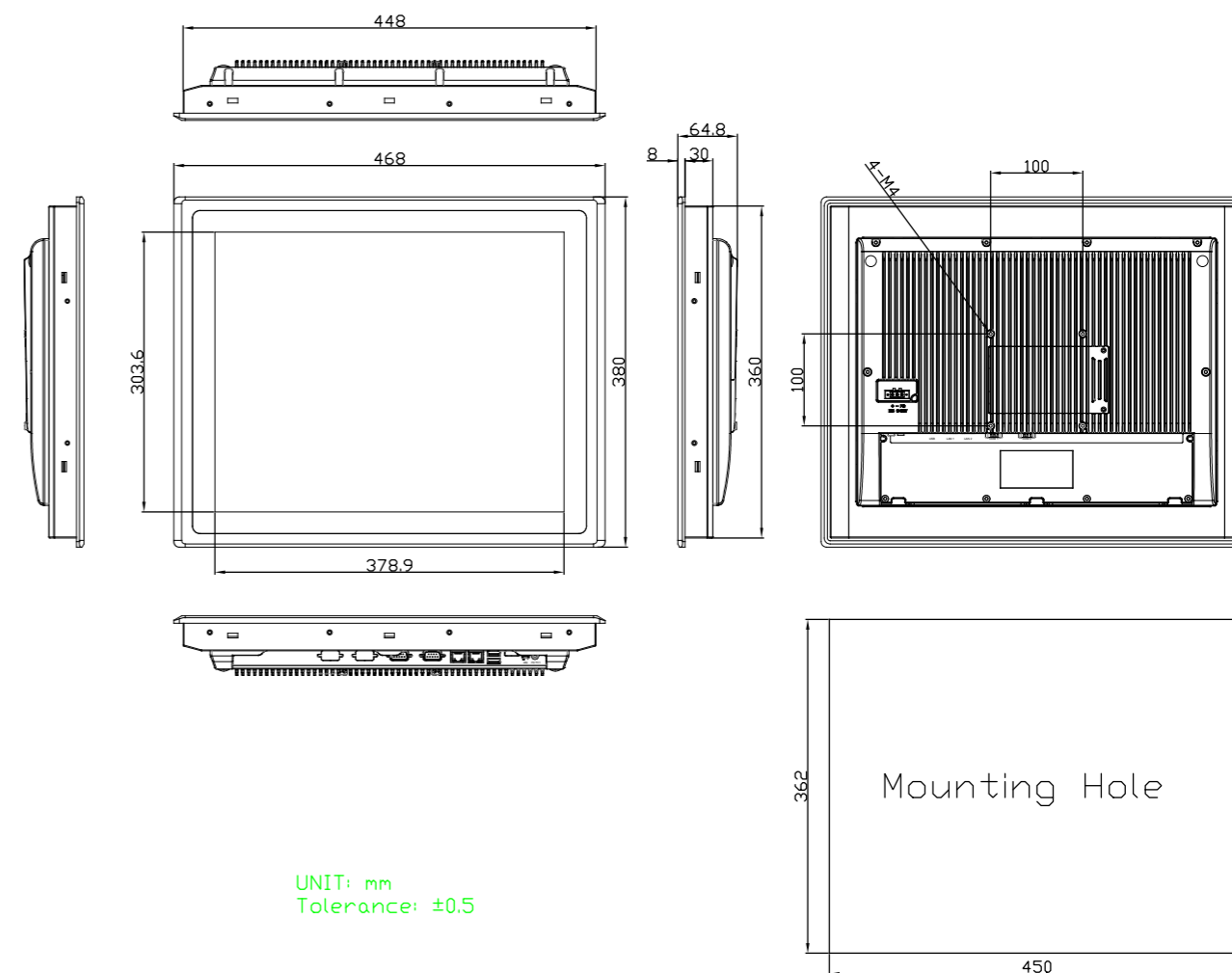

Power	
Power Input	DC 9~36V
Power Consumption	ARCHMI-819AR: 42W (MAX)
Mechanical	
Color	RAL 9007
Construction	Aluminum front bezel/ Aluminum die-casting for back cover
Mounting	Panel Mount, VESA 100 x 100
Dimensions (WxHxD)	468 x 380 x 64.8 mm
IP Rating	IP66 Compliant Front Bezel
Net Weight	7.2 kg
Environmental	
Operating Temperature	0~50°C
Storage Temperature	-30~70°C
Humidity	10 to 95%@ 40°C, non-condensing
Certificate	CE/FCC Class A
Operating System Support	
Windows 10 IoT	

*PoE limitation: CPU turbo off, rear I/O no loading, 70% LED backlight, PSE cable length < 50m