



# DATA SOUND - LABORATORIES -

.....  
EMBEDDING THE FUTURE



**Electronic  
Design**



**Panel  
PC / HMI**

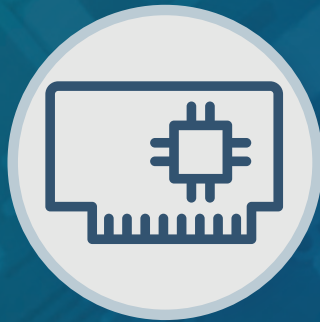

**Single Board  
Computer**



**Industrial  
PC**

## Why choose DSL?

- Over 30 Years Industry Experience
- 5 Years Warranty on all Products
- Evaluation Products Available
- Lifetime Technical Support

## Our Services

- Electronic Design
- Production Management
- Assembly and Test
- Bespoke BIOS Creation
- Industrial Embedded PC Solutions



Call us on +44(0)1462 675530



Email us at [sales@dsl-ltd.co.uk](mailto:sales@dsl-ltd.co.uk)



[www.dsl-ltd.co.uk](http://www.dsl-ltd.co.uk)

## Features

- 21.5" Industrial Compact Size Panel PC
- Intel Apollo Lake N4200/ N3350 (option)
- On Board 4GB/ 8GB DDR3L 1600MHz
- Flat front panel touch screen
- IP66 compliant front panel
- Optional projected capacitive touchscreen support 7H anti-scratch surface
- DC 9~36V wide-ranging power input
- High Brightness 1,000 nits for option

## Specifications

System	
CPU	Onboard Intel Apollo Lake N4200 (4 Core, 1.1GHz) / N3350 (2 Core, 1.1GHz) (option)
System Chipset	SoC
Memory	Onboard 4GB/ 8GB (option) DDR3L 1600MHz

I/O Port	
USB	2 x USB 3.0 type A
Serial / Parallel	1 x DB-9 RS-232/422/485, COM1 (Default RS-232) 1 x RS-232 DB-9, COM2
Audio	1 x Audio Line Out
LAN	2 x GbE LAN RJ-45
Power	1 x 3-pin DC power input terminal 1 x 2-pin connector for power on/off

Option	
	VESA Stand 4G LTE/Wi-Fi/BT 4 x USB 2.0 type A(TB-528U4) 4 x USB 2.0 type A + 1 x Mini PCIe + 1 SIM slot (TB-528U4ME1) 1 x COM(RS-232) + 2 x USB 2.0 (TB-528C1U2) 1 x COM(RS-232) + 2 x USB 2.0 + 1 x Mini PCIe + 1 x Power Button (TB-528C1U2P1) 2 x COM(RS-232) (TB-528C2) 2 x COM(RS-232) + 1 x Mini-PCIe slot + 1 x SIM slot (TB-528C2ME1) 2 x COM(RS-232/485, isolated) (TB-528C2I) 2 x CAN(TB-528CAN2) 1 x LAN + 2 x USB 2.0 (TB-528E1U2) <b>UPS Battery 21W/10.8W/1.95Ah(3S1P)</b>

Storage Space	
HDD	1 x 2.5" SATA HDD bay for SATA3 HDD (Easy Accessible)

Expansion	
Expansion Slot	1 x Internal Mini-PCIe slot full size 1 x SIM card holder / Micro SD card reader

Display	Standard	High Brightness Optional
Display Type	21.5" TFT-LCD	21.5" TFT-LCD
Max. Resolution	1920 x 1080	1920 x 1080
Max. Color	16.7M	16.7M
Luminance (cd/m <sup>2</sup> )	250	1000
View Angle	178(H) / 178(V)	178(H) / 178(V)
Contrast	3000:1	3000:1
Backlight Lifetime	30,000 hrs	50,000 hrs

## Dimensions

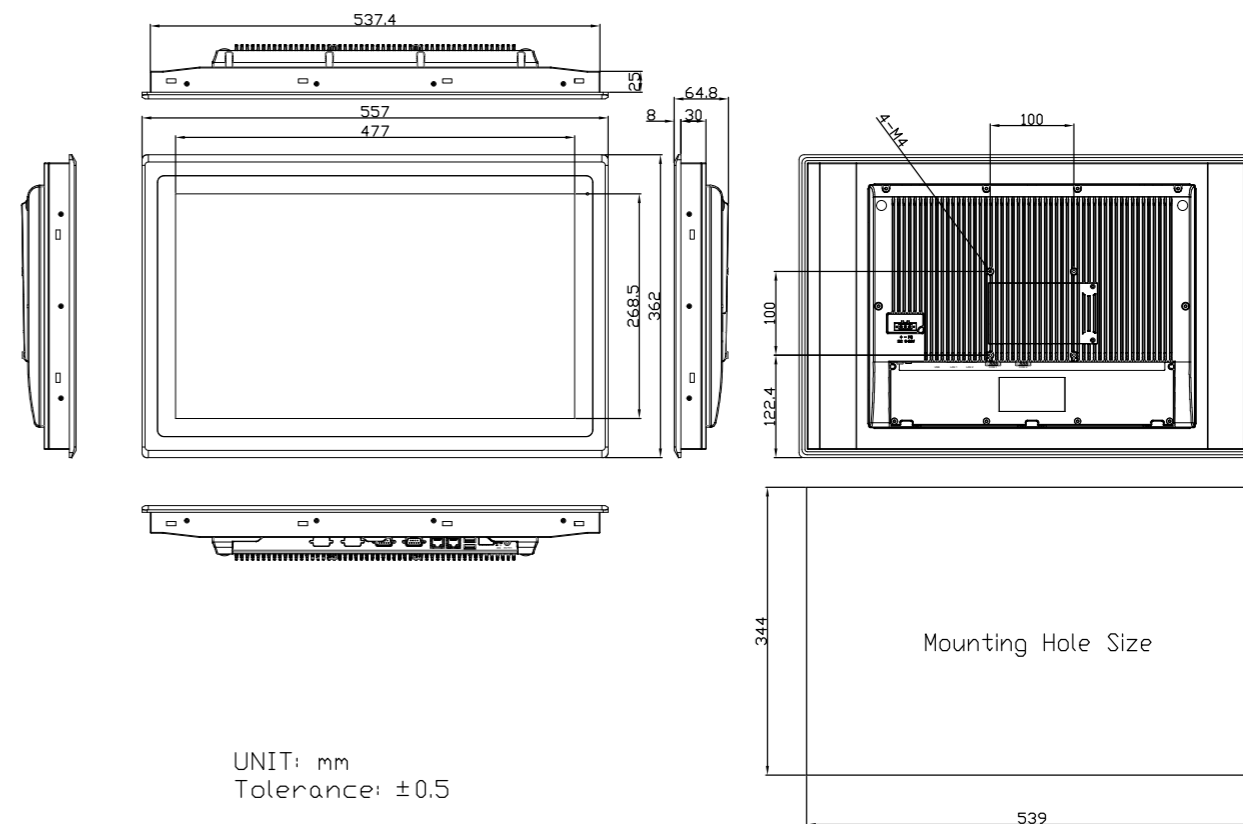

Touch Screen	
Type	Resistive Touch (for AR Model) Projected Capacitive Touch (for AP Model) Glass (for AG model)
Interface	USB
Light Transmission(%)	Resistive Touch Window: over 80% Projected Capacitive Touch: over 90%

Power	
Power Input	DC 9~36V
Power Consumption	ARCHMI-821AP: 43W (MAX)

Mechanical	
Color	RAL 9007
Construction	Aluminum front bezel/ Aluminum die-casting for back cover
Mounting	Panel Mount, VESA 100 x 100
Dimensions (WxHxD)	557 x 362 x 64.8 mm
IP Rating	IP66 Compliant Front Bezel
Net Weight	7.5 kg

Environmental	
Operating Temperature	0~40°C
Storage Temperature	-30~70°C
Humidity	10 to 95%@ 40°C, non-condensing
Certificate	CE/FCC Class A

Operating System Support	
	Windows 10 IoT Enterprise