



# DATASOUND - LABORATORIES -

.....  
EMBEDDING THE FUTURE



**Electronic  
Design**



**Panel  
PC / HMI**

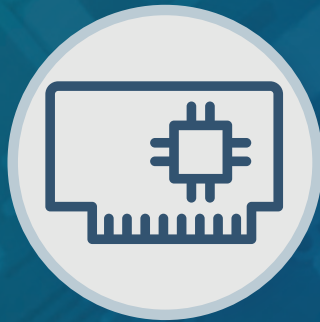

**Single Board  
Computer**



**Industrial  
PC**

## Why choose DSL?

- Over 25 Years Industry Experience
- 5 Years Warranty on all Products
- Evaluation Products Available
- Lifetime Technical Support

## Our Services

- Electronic Design
- Production Management
- Assembly and Test
- Bespoke BIOS Creation
- Industrial Embedded PC Solutions



Call us on +44(0)1462 675530



Email us at [sales@dsl-ltd.co.uk](mailto:sales@dsl-ltd.co.uk)



[www.dsl-ltd.co.uk](http://www.dsl-ltd.co.uk)

### Features

- 12.1" Industrial Compact Size Panel PC
- Intel 6th Gen. Core i3(standard) / i5(option) CPU built-in
- 1 x 260Pin SO-DIMM DDR4 up to 16GB 2133MHz
- Flat Front Panel Touch Screen
- Fanless Design
- DC 9~36V Wide-Ranging Power Input
- Optional Projected Capacitive Touch Screen Support 7H Anti-Scratch Surface
- High Brightness 1,000 nits for Option

### Specifications

System	
CPU	Onboard Intel 6th Gen. Core i3 CPU Processors/ i5(option)
System Chipset	SoC
Memory	1 x 260Pin SO-DIMM DDR4 up to 16GB 2133MHz
I/O Port	
USB	2 x USB 3.0 type A
Serial / Parallel	1 x DB-9 RS-232/422/485, COM1 (Default RS-232) 1 x RS-232 DB-9, COM2
Audio	1 x Audio Line Out
LAN	2 x GbE LAN RJ-45
Power	1 x 3-pin DC Power input terminal 1 x 2-Pin Power Switch
Option	2 x RS-232 DB-9 + 1 x Mini-PCIe slot via TB-528C2ME1 2 x CAN bus via TB-528CAN2 2 x USB 2.0 type A + 1 x Mini-PCIe slot + 1xRS-232 DB-9 via TB-528C1U2P1 2 x USB 2.0 type A Via TB-528U2 UPS battery 21W/10.8V/1.95Ah(3S1P)

Storage Space	
HDD	1 x 2.5" SATA HDD bay for SATA3 HDD (Easy Accessible)

Expansion	
Expansion Slot	1 x Internal Mini-PCIe slot full size

Display	Standard	High Brightness Optional
Display Type	12.1" TFT LCD	12.1" TFT LCD
Max. Resolution	800 x 600 1024 x 768 (optional)	800 x 600 1024 x 768 (optional)
Max. Color	262K / 16.2M (optional)	262K / 16.2M (optional)
Luminance (cd/m <sup>2</sup> )	450 / 500 (optional)	1000
View Angle	160(H) / 150(V) 160(H) / 140(V) (optional)	178(H) / 178(V) 160(H) / 140(V) (optional)
Contrast	800:1 / 700:1 (optional)	700:1
Backlight Lifetime	50,000 hrs 30,000 hrs (optional)	50,000 hrs
Option	Optical bonding	Optical bonding

Touch Screen	Resistive Touch	Projected Capacitive Touch
Interface	USB	USB
Light Transmission(%)	Over 80%	Over 90%

Power	
Power Input	DC 9~36V
Power Consumption	ARCHMI-912A: 45.54W

### Dimensions

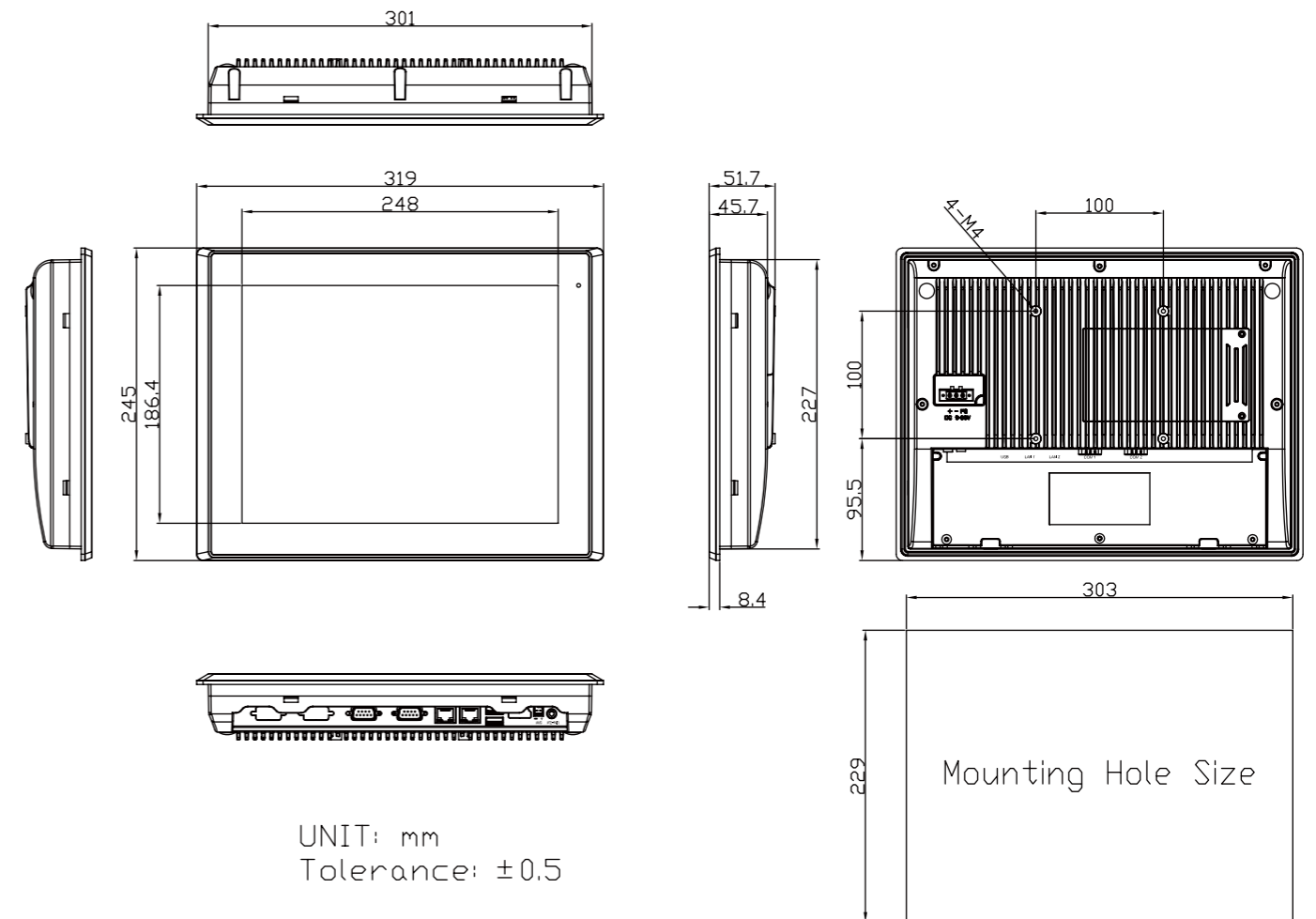

Mechanical	
Front Bezel	Flat Bezel design
Front Bezel Metal	Aluminum / Panel Mounting
Rear Panel Metal	Aluminum / VESA 100 x 100
Dimensions (WxHxD)	319mm x 245mm x 51.7mm
IP Rating	Front Panel IP66
Net Weight	2.8 kg

Environmental	
Operating Temperature	0~50°C
Storage Temperature	-20~60°C
Storage Humidity	10 to 90%@ 40°C, non-condensing
Certificate	CE / FCC, Class A

Operating System Support	
Windows 7 64 bit / Windows 8 64 bit / Windows 10 IoT 64 bit	

Ordering Information	
ARCHMI-912A-01	12.1" SVGA Fanless HMI barebone with Intel Core i3 CPU, 4GB DDR4 RAM, Resistive touch screen, 9~36V DC input with adapter, Aluminum chassis
ARCHMI-912AP-01	12.1" SVGA Fanless HMI barebone with Intel Core i3 CPU, 4GB DDR4 RAM, Projected Capacitive touch screen, 9~36V DC input with adapter, Aluminum chassis