



# DATASOUND - LABORATORIES -

.....  
EMBEDDING THE FUTURE



**Electronic  
Design**



**Panel  
PC / HMI**

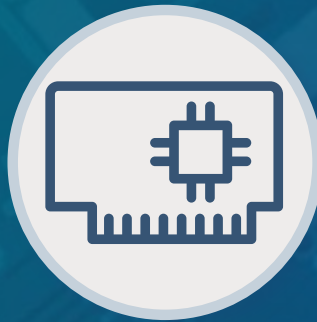

**Single Board  
Computer**



**Industrial  
PC**

## Why choose DSL?

- Over 25 Years Industry Experience
- 5 Years Warranty on all Products
- Evaluation Products Available
- Lifetime Technical Support

## Our Services

- Electronic Design
- Production Management
- Assembly and Test
- Bespoke BIOS Creation
- Industrial Embedded PC Solutions



Call us on +44(0)1462 675530



Email us at [sales@dsl-ltd.co.uk](mailto:sales@dsl-ltd.co.uk)



[www.dsl-ltd.co.uk](http://www.dsl-ltd.co.uk)

### Features

- 21.5" New Generation Stainless Steel Panel PC
- 11th Gen. Intel Core i3/i5 BGA type Processor
- True Flat Front Bezel Design and Grade 304 Stainless Steel Enclosure (Grade 316 for Option)
- IP66/IP69K Rated with M12 Connectors
- Ultra Slim Front Frame Design
- Special Hygienic Bolts on Rear Case
- Waterproof Wireless Antenna Covers to Solve the Bend Damage and Easy to Clean
- Support Ergonomic Versatile Mounting:  
VESA Mount 100 x 100 / Floor Stand / Swing ARM

### Specifications

System		
CPU	Onboard 11th Gen. Intel Core i3/i5 Processor Core i5-1145G7E (Quad Core, 8 MB cache, 1.50 GHz) Core i3-1115G4E (Dual Core, 6 MB cache, 2.20 GHz)	
System Chipset	SoC	
Memory	2 x 260-pin SO-DIMM up to 64GB DDR4 3200MHz	
TPM	TPM 2.0	
IO Port		
USB	1 x M12 8-pin for 2 x USB 2.0 with waterproof cover	
Serial / Parallel	1 x M12 8-pin COM1, RS-232/422/485, default RS-232, with waterproof cover	
LAN	1 x M12 8-pin for LAN with waterproof cover	
Power Connector	1 x M12 3-pin for DC power with waterproof cover 1 x Power switch on the rear	
Option	2 x optional blank M12 connector with waterproof cover for selecting two from the following options: 2 x USB 2.0 1 x USB 3.2 Gen.1 1 x HDMI 1 x LAN 1 x COM 1 x CAN	
Storage Space		
M.2	1 x M-Key 2280 (PCIe x4) for SSD	
Expansion		
Expansion slot	1 x Full size mPCIe/msATA (mPCIe as default, select by BIOS) 1 x NANO-SIM 1 x M.2 E-key 2230 (PCIe+USB) for optional WIFI/BT module	
RFID module	RFID module design on the front side (for option)	
Display		
	Standard	High Brightness Optional
Display Type	21.5" TFT-LCD	21.5" TFT-LCD
Max. Resolution	1920 x 1080	1920 x 1080
Max. Color	16.7M	16.7M
Luminance (cd/m <sup>2</sup> )	250	1000
View Angle	178(H)/178(V)	178(H)/178(V)
Contrast	1000:1	3000:1
Backlight Lifetime	50,000 hrs	50,000 hrs
Touch Screen		
Type	Resistive Touch (for CR model) Projected Capacitive (for CP model)	
Interface	USB	
Light Transmission(%)	Resistive Touch : 80% Projected Capacitive : 90%	

### Dimensions

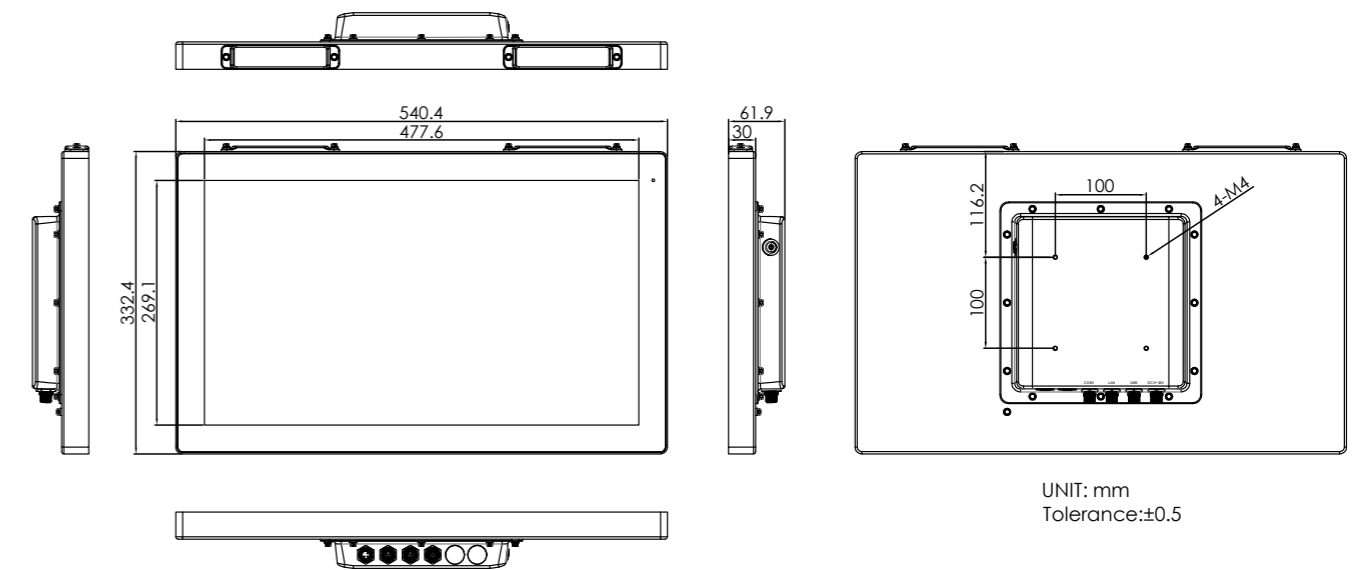

Power	
Power Input	DC 9~36V
Power Consumption	PhanTAM-921CP: 36W
Mechanical	
Construction	304 Stainless Steel Chassis (default), 316 Stainless Steel Chassis (optional)
Mounting	VESA Mount 100 x 100, Floor Stand / Swing ARM (optional)
IP Rating	Total IP66/IP69K
Dimensions	540.4 x 332.4 x 61.9 mm
Net Weight	7.9 kg
Environmental	
Operating Temperature	0~50°C (WT1: -20~60°C for optional)
Storage Temperature	-30~70°C
Humidity	10 to 90% @ 40°C, non-condensing
Certificate	CE/FCC Class A
Operating System Support	
Windows 10 IoT ENT LTSB, Windows 11	
Ordering Information	
PhanTAM-921CP	21.5" FHD IP66/IP69K stainless steel panel pc, Intel 11th Gen. Core i Processor, 2 x SO-DIMM DDR4 slots, 128GB TLC SSD, projected capacitive touch, 9~36V DC power input with Adapter
PhanTAM-921CR	21.5" FHD IP66/IP69K stainless steel panel pc, Intel 11th Gen. Core i Processor, 2 x SO-DIMM DDR4 slots, 128GB TLC SSD, 5 wire resistive touch window, 9~36V DC power input with Adapter
PhanTAM-921CPH	21.5" FHD IP66/IP69K stainless steel panel pc, Intel 11th Gen. Core i Processor, 2 x SO-DIMM DDR4 slots, 128GB TLC SSD, projected capacitive touch, 9~36V DC power input with Adapter, 1000 nits
PhanTAM-921CRH	21.5" FHD IP66/IP69K stainless steel panel pc, Intel 11th Gen. Core i Processor, 2 x SO-DIMM DDR4 slots, 128GB TLC SSD, 5 wire resistive touch window, 9~36V DC power input with Adapter, 1000 nits