



DATASOUND

- LABORATORIES -

.....

EMBEDDING THE FUTURE



**Electronic
Design**



**Panel
PC / HMI**

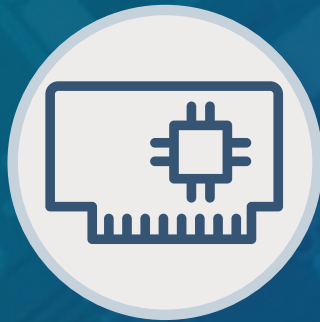

**Single Board
Computer**



**Industrial
PC**



Call us on +44(0)1462 675530



Email us at sales@dsl-ltd.co.uk

Why choose DSL?

- Over 25 Years Industry Experience
- 5 Years Warranty on all Products
- Evaluation Products Available
- Lifetime Technical Support

Our Services

- Electronic Design
- Production Management
- Assembly and Test
- Bespoke BIOS Creation
- Industrial Embedded PC Solutions



www.dsl-ltd.co.uk

Features

- 17" New Generation Stainless Steel Panel PC
- 8th Gen. Intel Core i3/i5 BGA type Processor
- True Flat Front Bezel Design and Grade 304 Stainless Steel Enclosure (Grade 316 for Option)
- IP66/IP69K Rated with M12 Connectors
- Support Resistive Touch, Projected Capacitive Touch
- Touch on/off Button on the Side Edge for Hygienic Cleaning
- Support Ergonomic Versatile Mounting: Yoke Mounting / Space-saving VESA 75 x 75 mm Mounting

Specifications

System	
CPU	Core i5-8365UE(Quad Core, 6 MB cache, 1.6GHz) Core i3-8145UE(Dual Core, 4 MB cache, 2.2GHz)
System Chipset	SoC
Memory	2 x 260-pin SO-DIMM up to 64GB DDR4 2400MHz

IO Port	
USB	1 x M12 8-pin for USB 2.0 with waterproof cover and chain
Serial / Parallel	1 x M12 8-pin COM1, RS-232/422/485, default RS-232, with waterproof cover and chain
LAN	1 x M12 8-pin for LAN with waterproof cover and chain
Others	1 x Touch on/off button at the side
Power Connector	1 x M12 3-pin for DC power with waterproof cover and chain 1 x Power switch on the rear
Option	2 x optional blank M12 connector with waterproof cover and chain for selecting two from the following options: 2 x USB 2.0 1 x USB 3.2 Gen.1 1 x LAN 1 x COM 1 x CAN

Storage Space	
HDD	1 x 2.5" SATA3 HDD (for option)
M.2	1 x B-Key 2280 (PCIe as default, SATA select by BIOS) for SSD

Expansion	
Expansion slot	1 x Full size mSATA/mPCIe (mSATA as default, select by BIOS) 1 x NANO-SIM 1 x M.2 E-key 2230 (PCIe+USB) for optional WIFI/BT module
RFID module	RFID module design on the front side (for option)

Display	Standard	High Brightness Optional
Display Type	17" TFT-LCD	17" TFT-LCD
Max. Resolution	1280 x 1024	1280 x 1024
Max. Color	16.7M	16.7M
Luminance (cd/m ²)	350	1000
View Angle	160(H) /140(V)	170(H) /160(V)
Contrast	800:1	800:1
Backlight Lifetime	50,000 hrs	50,000 hrs

Touch Screen	
Type	Resistive Touch (for BR model) Projected Capacitive (for BP model)
Interface	USB
Light Transmission(%)	Resistive Touch : 80% Projected Capacitive : 90%

Dimensions

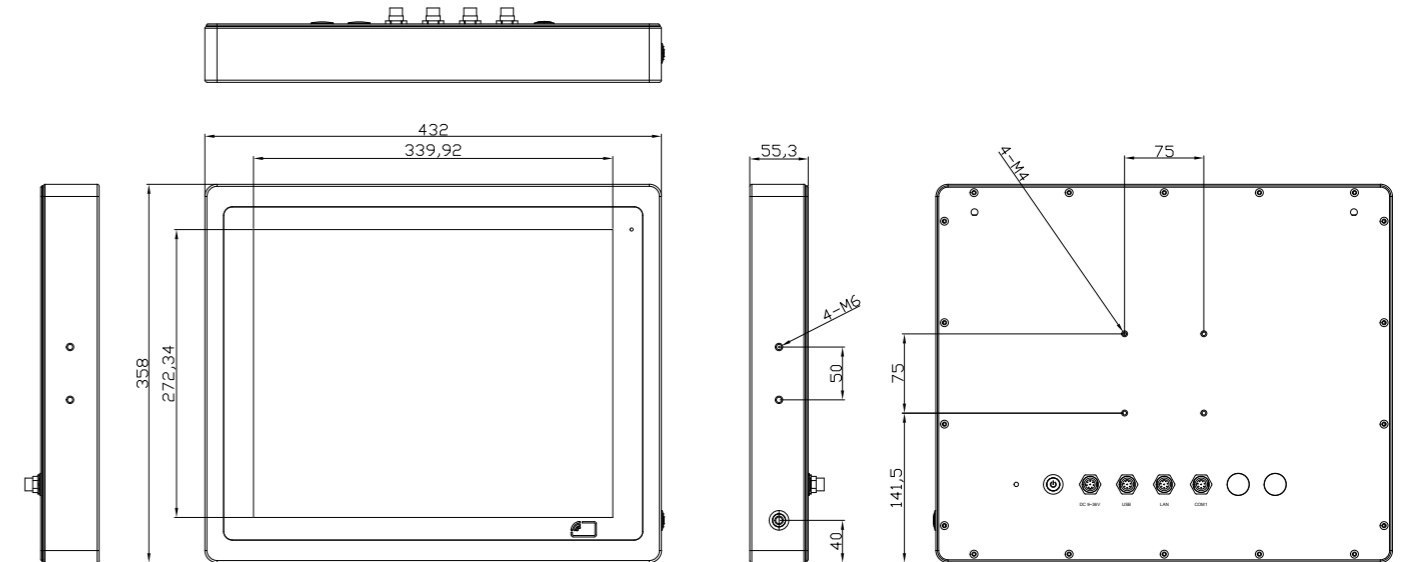

UNIT: mm
Tolerance: ±0.5

Power	
Power Input	DC 9~36V
Power Consumption	VITAM-917BP: 39W

Mechanical	
Construction	304 Stainless steel chassis(default), 316 Stainless steel chassis(optional)
Mounting	VESA mount 75 x 75, Yoke mount for optional
IP Rating	Total IP66/IP69K
Dimensions	432 x 358 x 55.3 mm
Net Weight	8 kg

Environmental	
Operating Temperature	0~50°C
Storage Temperature	-30~70°C
Humidity	10 to 95% @ 40°C, non-condensing
Certificate	CE/FCC Class A

Operating System Support	
Windows 10 IoT ENT LTSB	

Ordering Information	
VITAM-917BP	17" SXGA IP66/IP69K stainless steel panel pc, Intel 8th Gen. Core i Processor, 2 x SO-DIMM DDR4 slots, 128GB TLC SSD, projected capacitive touch, 9~36V DC power input with Adapter
VITAM-917BR	17" SXGA IP66/IP69K stainless steel panel pc, Intel 8th Gen. Core i Processor, 2 x SO-DIMM DDR4 slots, 128GB TLC SSD, 5 wire resistive touch window, 9~36V DC power input with Adapter
VITAM-917BPH	17" SXGA IP66/IP69K stainless steel panel pc, Intel 8th Gen. Core i Processor, 2 x SO-DIMM DDR4 slots, 128GB TLC SSD, projected capacitive touch, 9~36V DC power input with Adapter, 1000 nits
VITAM-917BRH	17" SXGA IP66/IP69K stainless steel panel pc, Intel 8th Gen. Core i Processor, 2 x SO-DIMM DDR4 slots, 128GB TLC SSD, 5 wire resistive touch window, 9~36V DC power input with Adapter, 1000 nits